

1	Pump
2	Boiler Input
3	Drain cock
4	Non-return valve
5	Expansion vessel
6	Pressure Gauge
7	Pressure relief valve
8	Safe Discharge
9	Fill point
10	Solar Panel
11	Viridian Controller
12	Hi-Limit Stat

ISSUE	DESCRIPTION	DATE	APPD
0	Original Issue		

Viridian Solar Differential Temperature Controller

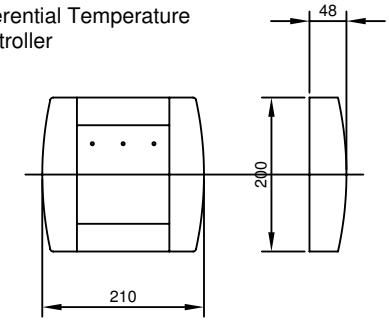

Typical Expansion Vessel Dimensions

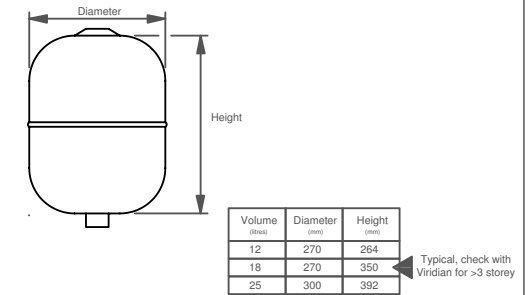

Viridian Solar
Brook Road, Bassingbourn,
Cambridgeshire, SG8 5NT
T 01763 653 007
www.viridiansolar.co.uk

TITLE Typical Fully Filled Solar Installation	
DRAWN SAE	DATE 19.06.2008
DRAWING NUMBER 100.001	SCALE